

trajet SPECIFICATIONS

BAHAMA 6032

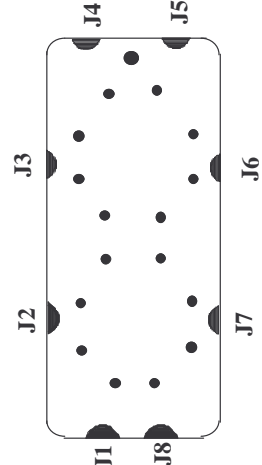
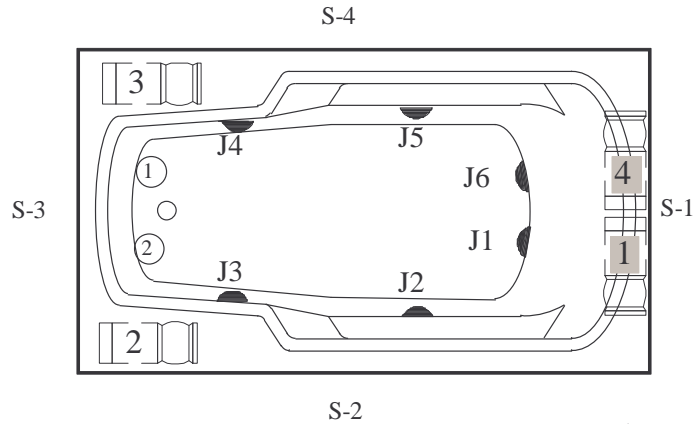
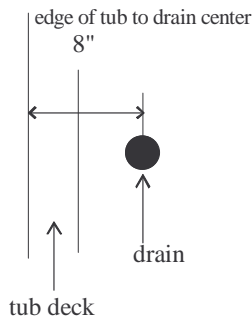
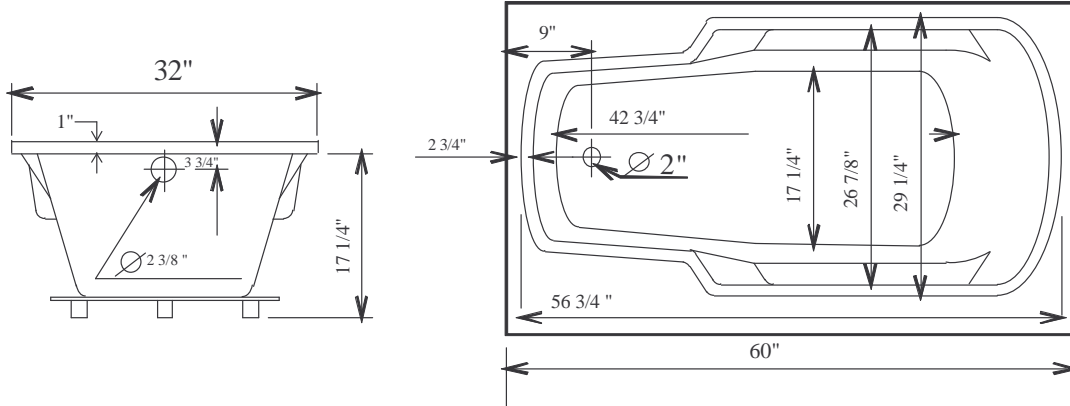

Deluxe--1.25 HP Pump, 6 Jets

Ultimate--1.5 HP Pump, 8 Jets, Electronic Control, Mood Light
 Jets are placed two on each side

Air System-- 120v Blower, 16 Air Jets, Electronic control
 Air jets are placed on bottom of tub in figure 8 pattern





If tub equipped with Air System Add 1.5" to tub height

Combo Systems:

Blower will be placed same side as pump opposite end

35 Min - 50 Max Gallon Capacity

Dimensional Variance +/- 1/2 "
 Suggested Pump Access Panel:
 20" Long x 12" High

- 
ADJUSTABLE JET
- 
MOTOR/PUMP
- 
OPTIONAL JET
- 
SIDE IDENTIFICATION