

trajet SPECIFICATIONS

6032 e³

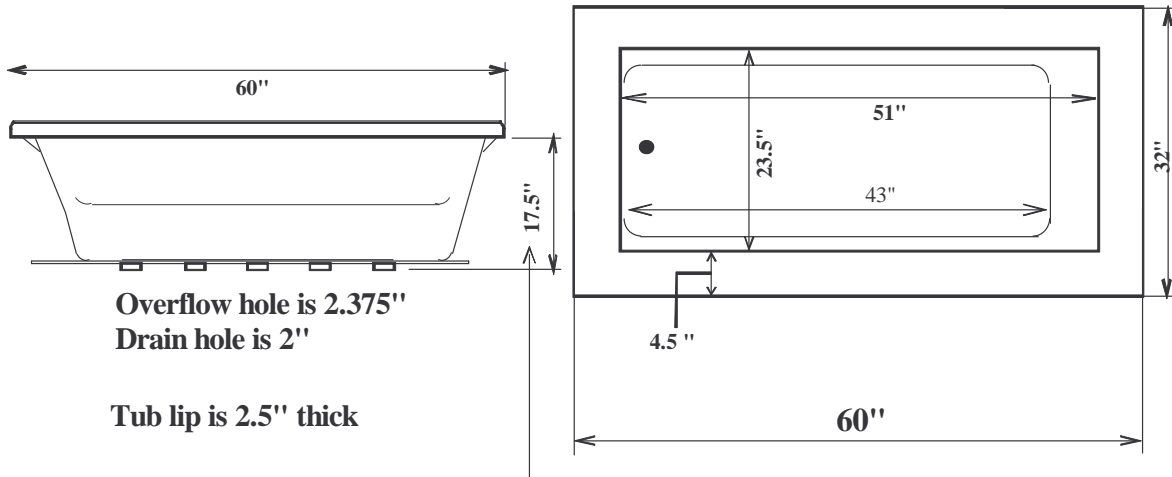

If tub equipped with Air System Add 1.5" to tub height

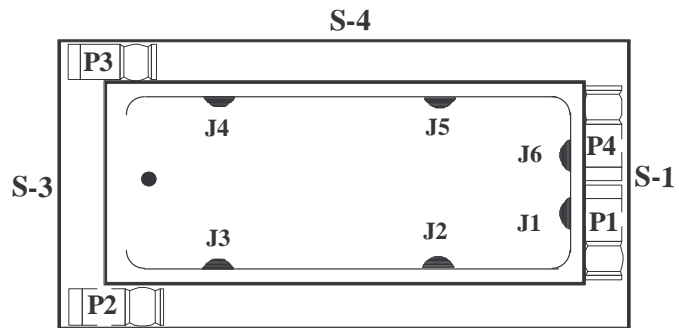
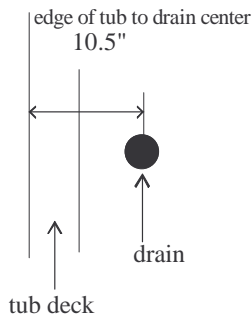

S-2

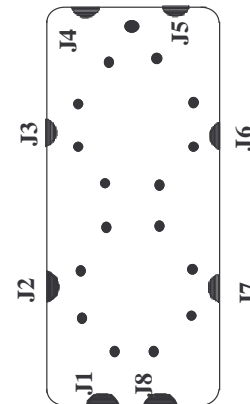

45 min - 60 Max gallon Capacity

Deluxe--1.25 HP Pump, 6 Jets

Ultimate--1.5 HP Pump, 8 Jets, Electronic Control, Mood Light

Jets are placed two on each side

Air System-- 120v Blower, 16 Air Jets, Electronic control

Air jets are placed on bottom of tub in figure 8 pattern

If tub equipped with Air System Add 1.5" to tub height

Combo Systems: blower will be placed same side as pump opposite end

Dimensional Variance +/- 1/2 "
 Suggested Pump Access Panel:
 20" Long x 12" High



ADJUSTABLE JET

S-1

SIDE IDENTIFICATION



MOTOR/PUMP



Air Jet