

trajet SPECIFICATIONS

6640 e¹

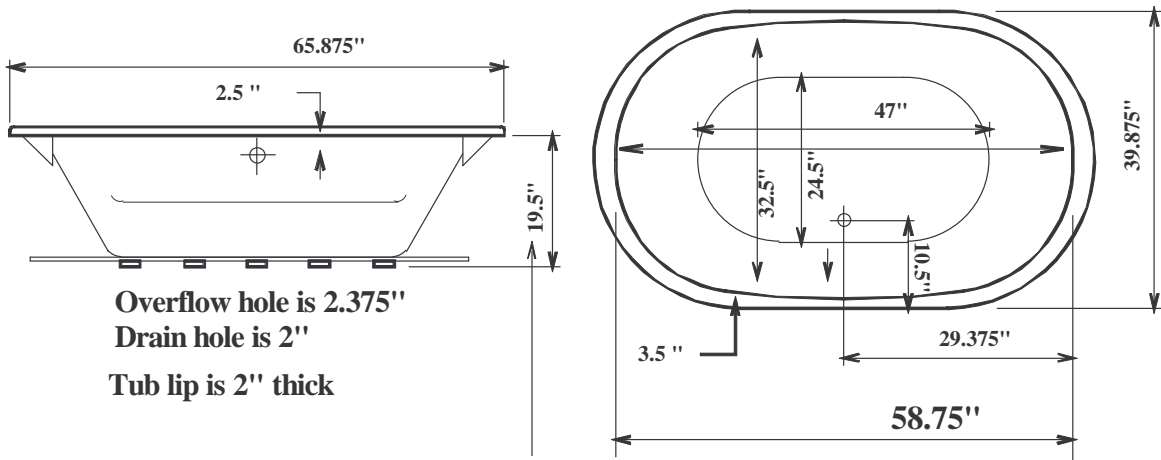

Overflow hole is 2.375"
 Drain hole is 2"
 Tub lip is 2" thick

If tub equipped with Air System Add 1.5" to tub height

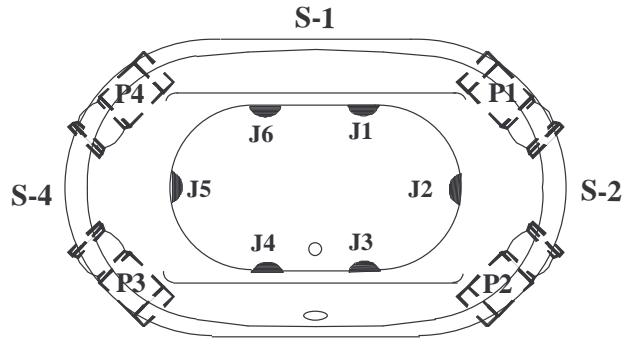
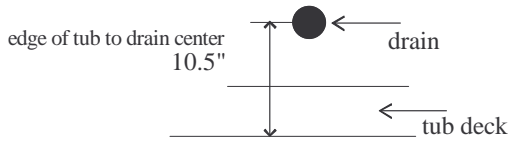

All pump positions extend beyond the perimeter of the tub deck.

50 Min - 95 Max Gallon Capacity

Deluxe--1.25 HP Pump, 6 Jets

Ultimate--1.5 HP Pump, 8 Jets, Electronic Control, Mood Light

Jets are placed two on each side

Air System-- 120v Blower, 16 Air Jets, Electronic control

Air jets are placed on bottom of tub in figure 8 pattern

If tub equipped with Air System Add 1.5" to tub height

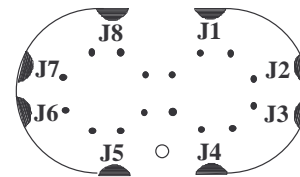

Combo Systems: blower will be placed same side as pump opposite end

Dimensional Variance +/- 1/2 "
 Suggested Pump Access Panel:
 20" Long x 12" High



ADJUSTABLE JET
 MOTOR/PUMP

S-1

SIDE IDENTIFICATION



Air Jet