

# trajet SPECIFICATIONS

7242 e<sup>2</sup>

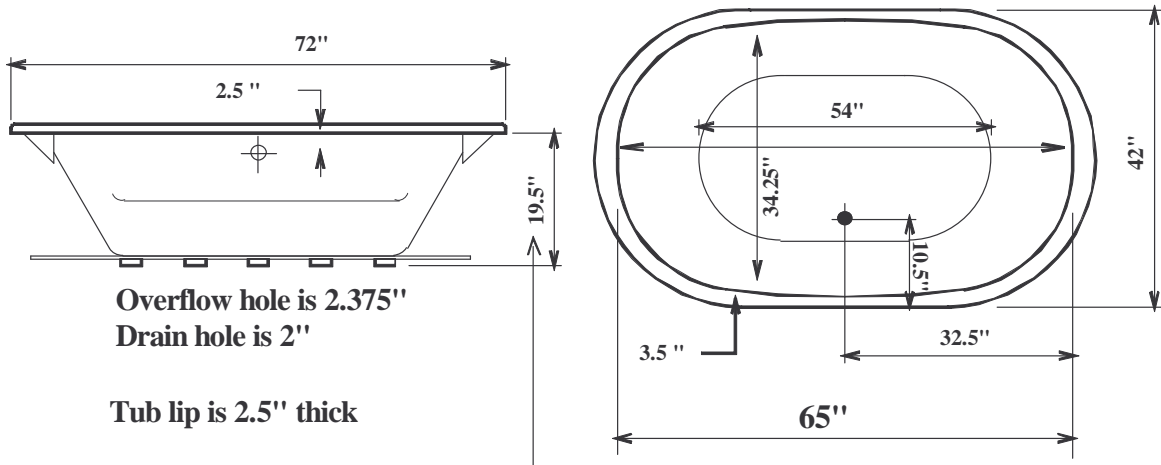

If tub equipped with Air System Add 1.5" to tub height

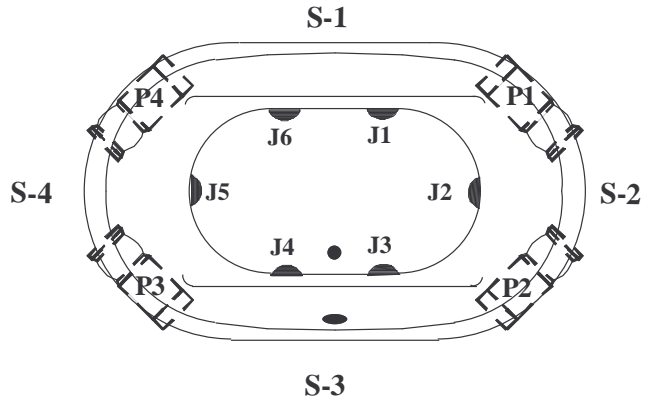
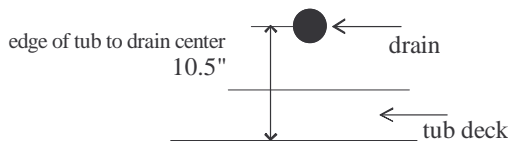

60 min - 100 Max gallon Capacity

Deluxe--1.25 HP Pump, 6 Jets

All pump positions extend beyond the perimeter of the tub deck.

Ultimate--1.5 HP Pump, 8 Jets, Electronic Control, Mood Light

Jets are placed two on each side

Air System-- 120v Blower, 16 Air Jets, Electronic control

Air jets are placed on bottom of tub in figure 8 pattern

If tub equipped with Air System Add 1.5" to tub height

Combo Systems: blower will be placed same side as pump opposite end

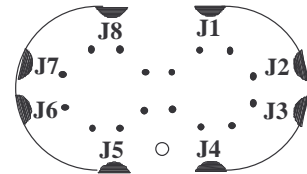

Dimensional Variance +/- 1/2 "

Suggested Pump Access Panel:  
20" Long x 12" High

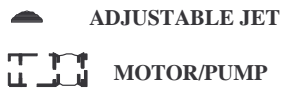

S-1 SIDE IDENTIFICATION

● Air Jet